

6040/6040 FS

Hydraulic Shovel



Engine*

Engine Model	2 × Cat® C32	
Gross Power – SAE J1995	1516 kW	2,032 hp
Net Power – SAE J1349	1516 kW	2,032 hp

*Electric drive option available (1400 kW) on 6040 AC/6040 AC FS

Bucket

Bucket Capacity – Front Shovel (heaped 2:1)	22.0 m ³	28.8 yd ³
Bucket Capacity – Backhoe (heaped 1:1)	22.0 m ³	28.8 yd ³

Operating Specifications

Bucket Payload	40 tonnes	44 tons
Operating Weight – Front Shovel	405 tonnes	446 tons
Operating Weight – Backhoe	407 tonnes	449 tons

6040/6040 FS Features

The model of reliability for Cat hydraulic mining shovels, the 6040/6040 FS offers improved uptime with a new undercarriage design, and enhanced safety with standard features designed in accordance with the principles of MDG 41 and 15. These upgrades, combined with proven features like TriPower (FS only), fully independent oil cooling, and the CAMP system, make this model a top performer in our hydraulic mining shovel line-up.

Contents

Drive Systems.....	4
Twin-engine Concept.....	5
TriPower System.....	6
Hydraulic System.....	8
Independent Oil Cooling System.....	9
Pump Managing System.....	10
Closed-loop Swing Circuit.....	11
Operator's Cab.....	12
Electronic Control System.....	13
Cat MineStar™ System and Technology Solutions.....	14
Loading/Hauling Efficiency.....	16
Front Attachment Options and Structures....	17
Swing System.....	18
Undercarriage.....	19
Safety.....	20
Serviceability.....	21
Customer Support.....	22
Sustainability.....	23
Specifications.....	24
Optional Equipment.....	31



Every Day Matters, Every Load Counts



We understand the challenges you face, the importance of reliability, and the relationship between uptime and productivity. That's why we continually strive to produce the safest, most reliable and productive hydraulic mining shovels possible. Offering the widest payload range of any manufacturer in the industry, the ability to optimally pair with our popular line of mining trucks, and the support of our world-class Cat dealer network, we are uniquely positioned to partner with you to help achieve your productivity targets. We understand what matters to you. Our hydraulic mining shovels are built with you in mind. Because in mining, every day matters and every load counts.

Drive Systems

Balanced Combination of Power and Efficiency



Meeting Your Site Specific Needs with a Choice of Robust Drive System Options

Giving you the option to choose the drive system best suited for your operation, the Cat 6040/6040 FS can be equipped with either two diesel engines for greater mobility, or an electric drive for better efficiency.

- **Reliable Cat C32 ACERT™ Engines**

Delivering durable, reliable power that will keep your primary loading tool producing, the C32 has proven its ability to perform in harsh mining conditions. Offering low operating costs, and supported 24/7 by your local Cat dealer, the C32 will help you achieve your production and profitability targets.

- **Efficient Electric Drive System on 6040 AC/6040 AC FS**

Providing a lower cost-per-ton alternative to diesel powered hydraulic mining shovels, our electric drive option maintains the ruggedness you need and offers superior availability since no refueling and less service is required.

The 6040 AC/6040 AC FS is the ideal solution for operations that do not require a great deal of mobility and value a low cost-per-ton model.



Twin-engine Concept

Stay Up and Running More Consistently

Keep Producing and Ensure the Safety of Your Operators, Even During Single Engine Loss

You will realize enhanced safety, greater uptime, more productivity, and better serviceability as a result of our twin engine concept.

- **Enhanced Safety**

The ability to move your shovel to a safe area for repair, away from high walls, blast zones, or other safety hazards, is still possible with the use of a single engine.

- **Greater Uptime and More Productivity**

65% of full production can still be achieved with the use of a single engine. This is due to the shovel's continued ability to exert maximum digging forces, to lower the front attachment without requiring engine power (i.e., pressure-free), and to recuperate energy via its closed-loop swing circuit.

- **Better Serviceability**

Troubleshooting is greatly simplified and expedited with the ability to compare one engine versus the other.



TriPower System

Superior Digging Capability and Bucket Fill Factors



Dig More Effectively with Our Unique TriPower Front Shovel Design

You will experience safer, easier and faster front shovel operation with TriPower, a system proven on over a thousand Cat hydraulic mining shovels worldwide. Generating superior mechanical leverage and control, our FS configured hydraulic mining shovels utilize a unique boom design that employs rotatable triangular rockers. This design facilitates quicker cycle times, increased effective lifting force, constant boom momentum, automatic constant bucket angle, and automatic roll-back limiter.

- **Quicker Cycle Times**

- Faster lifting speeds are achieved, because the design enables the use of smaller-diameter boom cylinders.

- **Increased Effective Lifting Force**

- Design transfers digging forces into the superstructure, creating supporting boom momentum in addition to momentum that is generated hydraulically.

- **Constant Boom Momentum**

- Allows smaller boom cylinders for higher lifting speed.
- Keeps lifting speed constant.
- Enables the shovel to lift a single load along the entire digging distance.
- No retracting of stick cylinders is required, ensuring that all hydraulic pumps are supplying the boom-up function.

- **Automatic Constant Bucket Angle**

- Material spillage is avoided during boom lifting, because the filled bucket automatically maintains a constant bucket angle.
- On conventional kinematics the operator has to control manually the bucket position during lifting which cut in half the available oil flow for the boom cylinders.

- **Automatic Roll-back Limiter**

- Preventing material spillage back on to the operator's cab and machine superstructure, our system ensures that the bucket is always in a safe position, without operator control/manipulation, when it is at maximum height.
- The boom cylinder continues to receive maximum oil flow, because the operator does not need to activate the bucket cylinder.



Hydraulic System

Easy Serviceability and Greater Productivity

Straightforward, Safe System Maintenance

Ensuring neat organization for safe operation, easy inspection, and fast service, and reducing the number of hoses needed, the main valve block is located on top of the boom.

Faster Cycle Times

Faster cycle times are realized, because float valves are used to lower the boom instead of engaging pumps. This facilitates faster boom movements and allows other operating functions to occur simultaneously, such as bucket curl and stick in/out.

Greater Control

Your operators will experience greater control with our five circuit hydraulics, allowing for two cylinder motions, two travel motions, and swing to be controlled simultaneously.

Independent Oil Cooling System

More Effective Oil Cooling for Extended Component Life



Protect and Extend the Life of Your Hydraulic Components and Seals

Providing a more efficient means of cooling, particularly in demanding applications, our unique independent oil cooling system will extend the life of your hydraulic mining shovel's components.

More Efficient Oil Cooling

Our system is independent of return oil, achieving efficiency through the utilization of dedicated pumps that provide cooling capacity as needed, whether the engine is idling or under load. That means optimum oil temperature is being maintained, even while your operator waits for the next truck to load. Competitive hydraulic mining shovels only provide cooling when the machine is working and the engine is under load.

Additional efficiency is achieved via our thermostatically controlled radiator fan speed. The fans do not run until oil temperature exceeds a temperature of 50° C (122° F), saving energy.

Optimal Oil Temperature Maintained

The highly efficient oil cooling system ensures that the oil temperature is only 25° C to 30° C (45° F to 54° F) higher than the ambient temperature. Thus the hydraulic oil working temperature remains within the optimal operating viscosity range of 50° C to 70° C (122° F to 158° F).

Experience Improved Machine Control and Component Life, while Reducing Fuel Consumption and Noise Emission, with Our Intelligent Pump Managing System

Delivering optimal performance, our pump managing system continuously evaluates actual engine and hydraulic operating values against set values, and adjusts pump output accordingly. This results in efficient use of the engine for greater productivity.

Pump managing system advantages include:

- Best possible utilization of engine output and engine overload avoidance via electronic load limit regulation
- Less energy consumption and less thermal load on hydraulic oil with zero oil flow regulation for main pumps
- Less fuel consumption and lower noise emission via automatic RPM reduction
- Reduced component wear and lower noise emission with automatic oil flow reduction for closing/opening of bucket clam
- Protection of components with automatic oil flow reduction if hydraulic and/or engine coolant temperature exceed set maximum
- Improved operator control response via on-demand pump flow

Pump Managing System

Enhanced Efficiency, Component Life,
and Control Response





Closed-loop Swing Circuit

More Efficient Energy Use and
Faster Boom Lift Motion During Swing

Load More Material, at Lower Cost, with the Energy Recovery Capability of our Closed-loop Swing System

Delivering faster cycle times and improved energy efficiency, while also generating less heat, our closed-loop swing circuit provides distinct advantages over competitive machines utilizing open-circuit swing systems.

Greater Efficiency Via Energy Recovery

Kinetic energy captured during the swing motion is fed back into the system during deceleration, providing more power to drive the main and auxiliary pumps. Energy is saved during deceleration, because braking occurs via counteracting controls, as opposed to throttles used in open circuit swing systems.

Energy Savings During Acceleration

Energy is saved during acceleration via torque control, providing a pressure balance valve that controls the swing pump against pressure in the closed-loop swing circuit, ensuring that only the minimum necessary oil flow is utilized at any given time.

Faster Cycle Times

Faster boom lift motion during swing is achieved with our closed-loop swing system, increasing overall productivity.

Operator's Cab

Ensuring the Safety and Comfort of Your Operators



Get Peak Operator Performance with Our Safe and Comfortable Operator's Cab.

We understand that the most important factor in your hydraulic shovel's effectiveness is the performance of its operator. To help make their workday as productive as possible, we've incorporated safety and comfort features into the 6040/6040 FS operator's cab.

Protection for Your Operator; Every Day, Every Shift

- Safety glass is used for all cab windows, and armored glass for the windshield.
- Operator's seat is equipped with integrated safety switch that automatically neutralizes the hydraulic controls when the operator leaves the seat.
- Position of cab module, approximately 6.8 m (22 ft 4 in) high, provides excellent visibility of the digging and loading areas.
- Cab meets Falling Object Protection System (FOPS) and DIN ISO 3449 standards.

Supporting Peak Operator Performance with Comfort Features

- Pneumatically cushioned, multi-adjustable operator's seat.
- Large, transfective color touch-screen display (BCS III) provides vital machine monitoring and diagnostic data for convenient troubleshooting and service assistance.
- Enhanced control response and servo adjustment capability via electro-hydraulic servo control.

Electronic Control System

Operate with Confidence



Enhanced Control Response and Optimized Hydraulic Engine Load Management

Help your team meet productivity and performance standards with our intuitive, informative on-board electronics.

Electro-hydraulic Servo Control

• Enhanced Control Response

The system relays actuating signals from the joysticks, delivering fast and precise machine reactions that reduce operator fatigue.

• Increased Uptime

Uptime is increased as a result of simplified troubleshooting and advanced diagnostic capabilities.

• Greater Operator Comfort

Easier setting of servo control characteristics allow operators to adjust to their preference.

• Clean and Quiet Cab Environment

No hydraulic lines are present in the cab or the cab module, ensuring a clean arrangement with less noise emission.

Control and Monitoring Platform (CAMP)

• Reduced Control System Inventory

Streamlined system requires only one type of controller for each function (i.e., left side drive train, right side drive train, servo, and auxiliary) reducing the number of required controllers in the system and associated replacement stock.

• Less Fuel Consumption

Engine works in optimal range of performance during the entire digging cycle, reducing fuel burn.

• Increased Component Life

Reduced hydraulic pulsation lessens stress imposed on the engine and hydraulic components.

• Enhanced Operator Comfort

Less vibration and more even machine movement via reduced pressure peaks.

• On-screen Documentation

The Parts book, Technical handbook, and Operating handbook, as well as hydraulic and electric schematics, are available in electronic format.

Cat MineStar System and Technology Solutions

Evolving Your Mine for Greater Safety and Productivity



Helping You Enhance Safety and Productivity Through Technology

Aimed at enhancing the productivity and profitability of your hydraulic mining shovel, we currently offer a combination of Cat MineStar System offerings and Cat hydraulic mining shovel technology solutions.

Cat MineStar System

Helping you achieve your goals for enhanced mine site safety, improved efficiency, reduced operating costs, and greater profitability, the Cat MineStar System provides the most comprehensive suite of mining technology products in the industry. It consists of a number of configurable capability sets – Fleet, Terrain, Detect, Health, and Command – that allow you to scale the system to your mine site needs. Cat MineStar System helps you manage everything from material tracking to sophisticated real-time fleet management, machine health systems, autonomous equipment, and more.

The Cat 6040/6040 FS is currently able to utilize three of the Cat MineStar System capability sets:

- **Fleet**

Fleet provides real-time machine tracking, assignment and productivity management, providing a comprehensive overview of all your asset operations from anywhere in the world.

- **Terrain**

Terrain enables high-precision management of drilling, dragline, grading and loading operations through the use of guidance technology. It increases machine productivity and provides you real-time feedback for improved efficiency.

- **Detect**

Detect provides equipment operators with enhanced awareness for increased site safety, using a combination of radars, an in-cab display, and multiple cameras.

The remaining Cat MineStar System capability sets are currently under development for the Cat hydraulic mining shovel product line.

Hydraulic Mining Shovel Technology Solutions

- **Monitoring and Diagnostic System**

Enhancing diagnostic capabilities and providing detailed troubleshooting functions, our Board Control System uses sensors throughout the machine to monitor operating data, record faults, and notify the operator audibly and visually. This promotes the earliest possible detection of faults and allows for timely maintenance planning and assistance for speedy repair.



Loading/Hauling Efficiency

Move More Material with Optimal Pass Match Pairings



Achieve Targeted Loading/Hauling Production with Perfectly Paired Cat Hydraulic Mining Shovels and Mining Trucks

For full truck payloads with minimum loading time, an efficient loading/hauling system begins with an optimized equipment match. Cat hydraulic mining shovels are matched with Cat mining trucks to maximize volume of material moved at the lowest operating cost per ton.

6040/6040 FS Pass Match with Cat Mining Trucks

	785D/785C	789D	MT4400D AC	793F/793D
	136 tonne (150 ton)	181 tonne (200 ton)	221 tonne (244 ton)	227 tonne (250 ton)
6040/6040 FS	4	5	6	6

Front Attachment Options and Structures

Bolstering Your Investment with Robust and Durable Structures



Rugged Front Attachment Options Designed and Fabricated to Withstand Your Extreme Mining Conditions

To extend service life and ensure that your shovel keeps producing, our front shovel attachment structures are designed for durability and dependability. Extended performance in the harsh mining conditions you face daily is accomplished through selection of high-strength steels and rugged castings, joined and thermally stress-relieved, to help you achieve your productivity targets.

Front Attachment Structures Include:

- Heavy castings at all pivot points
- Better flow of forces and less welding seams, as top chords are made of one bend plate
- Entire boom and stick are stress relieved after welding
- Welding procedures allow for internal welding (double prep weld)



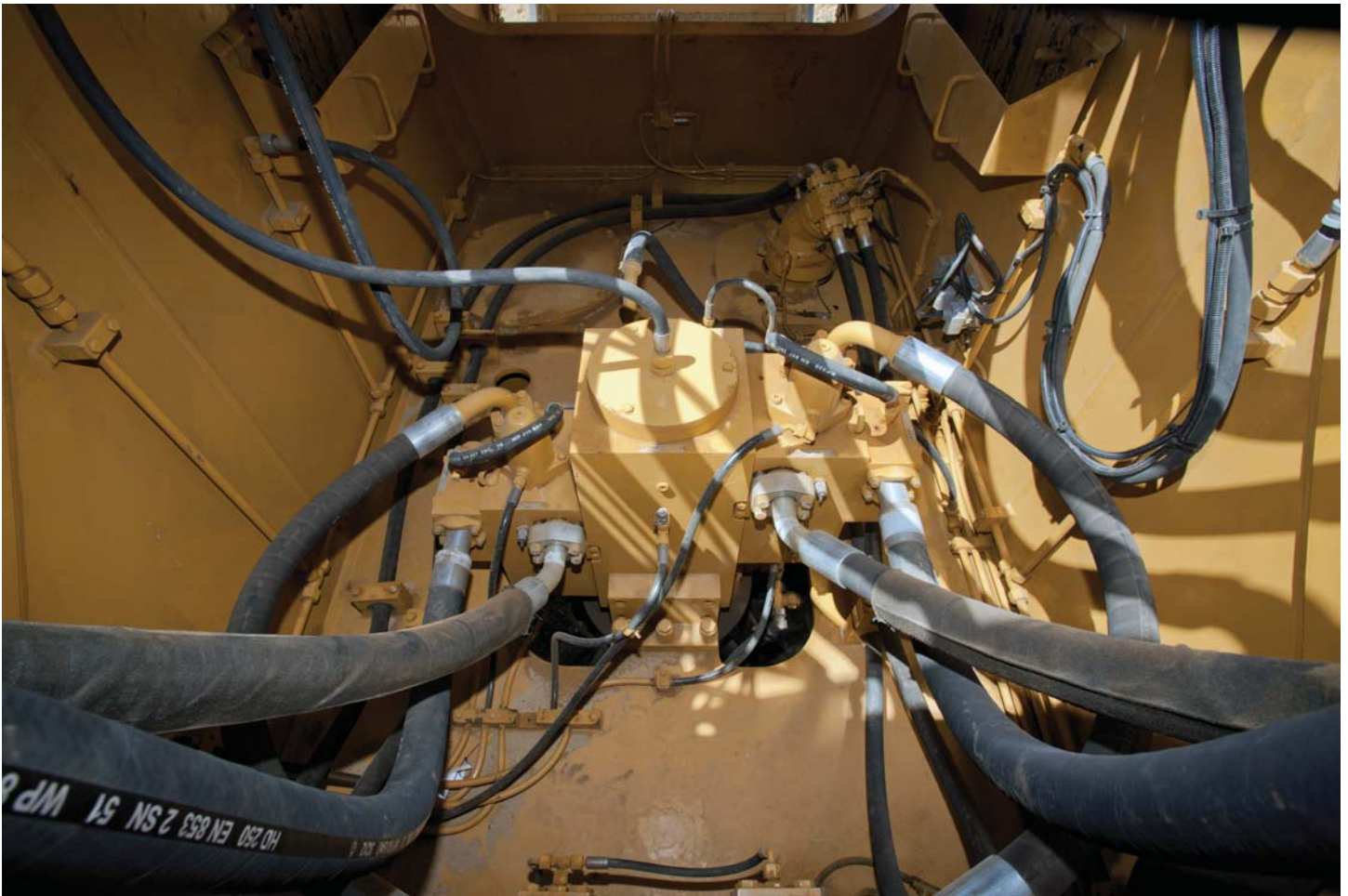

Swing System

Longer Component Life for Better
Swing System Reliability

More Reliable Swing Component Life

Extending component life and ultimately improving machine uptime, our swing system includes a triple-race swing roller bearing with internal gearing connected to an automatic lubrication system.

For added reliability, all lube lines are located inside the roller bearing for maximum protection.

Service Friendly

Easier maintenance is afforded by the free accessibility of swing gears and rotary distributor.

Less Wear and Tear on Crawler Components

Extending track life and improving overall machine reliability, our undercarriages are engineered with extensive use of finite element analysis, steel structures are optimized, travel motors are well-protected by strong cover plates and hinged door covers, and a unique robust track chain incorporates a combined pad/link design. Further extending track life, a state-of-the-art track tensioning system with membrane accumulator automatically adapts the tensioning of the tracks, depending upon operating conditions.



Undercarriage
Tough and Long-lasting

Safety

Designed with Your Safety as Our Top Priority



Sharing your commitment to safety, and driven by our commitment to Zero Harm, we work tirelessly to design the safest machines possible to protect your most important asset; your employees. That is why we updated the design of the 6040/6040 FS in accordance with the principles of MDG 41 and 15, and offer this standard, not as an option or upgrade.

Some examples of the safety-enhancing features of the Cat 6040/6040 FS hydraulic mining shovel include the following:

Machine Access

- All stairways have 45° angle for safe and comfortable access and movement about the machine.
- Slide down emergency egress ladder directly adjacent to the operator's cab.
- Hydraulically operated boarding ladder with emergency lowering via nitrogen accumulator ensures that ladder remains operational even when engines shut off.
- Machine swing and propel capability is switched-off when ladder is in down position.

Service and Maintenance

- Improved routing and clamping of hydraulic hoses.
- Hydraulic hoses and electrical wiring are separated from each other for fire prevention.
- All service areas are accessible via anti-slip walkways, and trip hazards are eliminated.
- All hot surfaces are covered to prevent burns.

Electrical System

- Cabinet with battery isolation switch, mounted on top deck directly above the battery box, allows quick and easy shut-off of voltage on the entire shovel.
- Cabinet contains a starter isolator which allows on-board voltage, but prevents starting of engines.

Emergency Shut-offs

- An easily accessible, standard shut-off switch located in the cab shuts down the electrical system in case of emergencies.
- Additional shut-off switches are located on the machine, in the machine house or accessible from the ground with pull ropes.

Precise Bucket Control

- Minimizing the potential for material spill onto the attachment or cab, the TriPower automatic roll-back limiter prevents the bucket from being curled back too far.



Serviceability

Designed to Get You Back to Work Fast



Lowering your operating costs and maximizing your hydraulic mining shovel's uptime and productivity is of supreme importance to us. To that end, we've made vital components more accessible and designed simpler systems to make maintenance activities quicker and easier.

Open, Spacious Access to Components

- Facilitating easier maintenance, exceptional accessibility is provided to systems like the swing motor, swing gearbox and rotary distributor in the well organized superstructure. The engine is accessible from three sides.
- Easily accessed by walkways on both sides, the boom-mounted main valve block, a feature unique to Cat hydraulic mining shovels, provides a clean layout and reduces the number of hoses leading from the superstructure to the attachment.

Simple Hydraulic System with Main Valve Block Positioned on Boom

- Ensuring neat organization for safe operation, easy inspection and fast service, the design of our hydraulic system significantly reduces the total number of frequently moving hoses from the superstructure to the attachment.
- Longer hose life via improved routing in accordance with MDG design standards.

Easy Ground-level Fuel and Fluid Replenishment

- Quick fuel and fluid replenishment is made easy with a retractable service station underneath the engine module, accessible at ground-level.

Improved Drive Train Troubleshooting

- Twin-engine design facilitates troubleshooting of drive trains, as one engine can be compared to the other.



Customer Support

Stay Up and Running with Service and Support from Our Unmatched Global Network

Commitment Makes the Difference

Cat dealers offer a wide range of solutions, services and products that help you lower costs, enhance productivity and manage your operation more efficiently. From the time you select a piece of Cat equipment until the day you trade or sell it, the support you get from your Cat dealer makes the difference.

Dealer Capability

Cat dealers provide the level of support you need, on a global scale. Dealer expert technicians have the knowledge, experience, training and tooling necessary to handle your repair and maintenance needs, when and where you need them.

Product Support

When Cat products reach the field, they are supported by a worldwide network of parts distribution facilities, dealer service centers and technical training facilities to keep your equipment up and running.

Cat customers rely on prompt, dependable parts availability through our global dealer network, ready to meet your needs 24/7.

Service Support

Every piece of Cat equipment is designed and built to provide maximum productivity and operating economy throughout its working life. Cat dealers offer a wide range of service plans that will maximize uptime and return on your investment, including:

- Preventive Maintenance Programs
- Diagnostic Programs, such as Scheduled Oil Sampling and Technical Analysis
- Rebuild and Reman Option
- Customer Support Agreements

Application Awareness

Operating and maintenance costs are influenced by many application and site-specific factors, such as: material density and fragmentation, payload, bench height, truck positioning, ground conditions, amount of traveling and maintenance. Your Cat dealer can provide you with an understanding of the effects application characteristics and operating techniques have on maintenance and operating costs.

Operation

Your Cat dealer can arrange training programs to help operators improve productivity, decrease downtime, reduce operating costs and enhance safety.

Sustainability

Higher Standards for a Better Tomorrow



Meeting the needs of today without compromising the needs of tomorrow is the goal for all Cat machinery. The commitment to helping you operate safely and sustainably is affirmed in the production of the 6040/6040 FS hydraulic mining shovel.

Cat Hydraulic Mining Shovel Sustainability:

- **Electric Power Option**

Produces less emissions, heat, and sound, and avoids disposal/replenishment of engine oil and oil filters.

- **Energy Recovery**

Emit less heat and improve energy efficiency via the energy recovery capability of the closed-loop swing circuit.

- **Rebuilds**

Decrease your energy use and material consumption with a machine that's designed to be rebuilt.

6040/6040 FS Hydraulic Shovel Specifications

General Data

Operating Weight		
Face Shovel	405 tonnes	446 tons
Backhoe	407 tonnes	449 tons
Engine Output SAE J1995		
Cat C32	1516 kW	2,032 hp
Standard Bucket Capacity		
Face Shovel (heaped 2:1)	22.0 m ³	28.8 yd ³
Backhoe (heaped 1:1)	22.0 m ³	28.8 yd ³

Features

- TriPower shovel attachment
- Independent oil cooling system
- Spacious walk-through machine house
- 5-circuit hydraulic system
- On-board electronics system:
Control and Monitoring Platform (CAMP)
- Board Control System (BCS III)
- Torque control in closed-loop swing circuit
- Automatic central lubrication system
- LED working lights

Operating Weight

6040 FS		
Standard track pads	1200 mm	3 ft 11 in
Operating weight	404 600 kg	891,980 lb
Ground pressure	24.1 N/cm ²	35.0 psi

- Other track pads available on request

6040		
Standard track pads	1200 mm	3 ft 11 in
Operating weight	407 300 kg	897,930 lb
Ground pressure	24.3 N/cm ²	35.3 psi

- Other track pads available on request

Diesel Engines

Make and model	2 × Cat C32 (Tier 2)	
Total rated net power ISO 3046/1	1516 kW	2,032 hp
	1,750 min ⁻¹	1,750 min ⁻¹
Total rated net power SAE J1349	1516 kW	2,032 hp
	1,750 min ⁻¹	1,750 min ⁻¹
Total rated gross power SAE J1995	1516 kW	2,032 hp
	1,750 min ⁻¹	1,750 min ⁻¹
No. of cylinders (each engine)	12	
Bore	145 mm	5.71 in
Stroke	162 mm	6.38 in
Displacement	32.1 L	1,959 in ³
Aspiration	Turbocharged and air-to-air aftercooled	
Max. altitude without deration – at 10° C above sea level	2500 m	8,200 ft
Emissions	U.S. EPA flex	
Alternators	2 × 150 A	
Fuel tank capacity	7800 L	2,060 gal

- Hydraulically driven radiator fan with electronically controlled fan speed
- Microprocessed engine management
- Heavy-duty air filters
- Two-stage fuel filter including water separator
- Additional high-capacity water separator

Electric Motor – 6040 AC/6040 AC FS

Type	Squirrel cage induction motor
Output	1400 kW
Voltage	6.6 kV ± 10% (other on request)
Rated Current I _N	156 A (at 6.6 kV)
Frequency	50 Hz (60 Hz on request)
Revolutions	1,500 min ⁻¹ (1,800 min ⁻¹ at 60 Hz)
Starting current	350% of I _N (197% of I _N Optional)

- Custom-made electric motor with increased gap between rotor and stator to withstand severe mining conditions
- Power limit control by Pump Managing System

Electrical System (diesel drive)

System voltage	24V
Batteries in series/parallel installation	6 × 210 Ah – 12V each 630 Ah – 24V in total

- Battery isolation relays and switches
- Emergency stop switches accessible from ground level, in engine module and in operator's cab
- 10 LED high-brightness working flood lights
 - 8 for working area
 - 2 for rear end
- 2 LED high-brightness access flood lights
- 13 LED service lights

6040/6040 FS Hydraulic Shovel Specifications

Hydraulic System with Pump Managing System

Main pumps

Diesel version	4 × variable swash plate pumps	
AC version	4 × variable flow axial piston pumps	

Maximum oil flow

Diesel version	4 × 724 L/min	4 × 191 gal/min
AC version	4 × 746 L/min	4 × 197 gal/min

Maximum pressure, attachment	300 bar	4,350 psi
------------------------------	---------	-----------

Maximum pressure, travel	350 bar	5,080 psi
--------------------------	---------	-----------

Swing pumps

Diesel version	4 × reversible swash plate pump	
AC version	3 × reversible swash plate pump	

Maximum oil flow

Diesel version	4 × 321 L/min	4 × 85 gal/min
AC version	3 × 491 L/min	3 × 130 gal/min

Maximum pressure, swing pumps	350 bar	5,080 psi
-------------------------------	---------	-----------

Total volume of hydraulic oil – approximately

Diesel version	5800 L	1,532 gal
AC version	6400 L	1,585 gal

Hydraulic tank capacity – approximately

Diesel version	3400 L	898 gal
AC version	4000 L	1,057 gal

- Pump Managing System contains:
 - Electronic load limit control
 - Flow on demand from main pumps depending on joystick position
 - Automatic regulation of main pumps to zero flow without demand
 - Automatic rpm reduction of engine speed during working breaks
 - Reduced oil flow of main pumps at high hydraulic oil temperature or at high engine temperature
- Pressure cut-off for main pumps
- Cooling of pump transmission gear oil
- Filters:
 - Full-flow high-pressure filters (100 µm) for the main pumps, installed directly behind each pump
 - Full-flow filters (10 µm) for the complete return circuit
 - Full-flow filters (10 µm) for the cooling return circuit
 - Pressure filters (6 µm) for servo circuit
 - Pressure filters (40 µm) for the feed pumps of the closed swing circuit
 - Transmission oil filters (40 µm)

Hydraulic Oil Cooling

Oil flow of cooling pumps

Diesel version	2 × 799 L/min	2 × 211 gal/min
AC version	4 × 379 L/min	4 × 100 gal/min

Diameter of fans	2 × 1524 mm	2 × 60 in
------------------	-------------	-----------

- Cooling system is fully independent of all main circuits, i.e. controlled cooling capacity is available whenever engine is running
- Gear type cooling pumps supplying high-volume, low-pressure oil to aluminum coolers
- Variable axial piston pumps supplying low-volume, high-pressure oil to fans
- Fan speed is thermostatically controlled
- Extremely high cooling efficiency to ensure optimum oil temperature

Swing System

Swing drives	3 compact planetary transmissions with axial piston motors
--------------	--

Parking brake	Wet multiple disc brake, spring-loaded/hydraulically released
---------------	---

Maximum swing speed

Diesel version	4.7 rpm
AC version	5.1 rpm

Swing ring	Triple-race roller bearing with sealed internal gearing
------------	---

- Closed-loop swing circuit with torque control
- Hydraulic braking of the swing motion by counteracting control
- All raceways and the internal gearing of swing ring supplied by automatic central lubrication system
- Dirt wipers at swing ring to prevent build-up of debris between swing ring and carbody

Retractable Service Station

Retractable service station installed underneath the engine module and easily accessible from ground

Equipped with:

- Quick couplings for:
 - Diesel fuel
 - Engine coolant – left/right
 - Pump transmission gear oil – left/right
 - Engine oil – left/right
 - Hydraulic oil tank
 - Grease container
- Cat jump-start socket
- Indicator lights for fuel tanks left/right full and grease container full

6040/6040 FS Hydraulic Shovel Specifications

Operator's Cab

Operator's eye level – approximately	6.8 m	22 ft 4 in
Internal dimensions of cab		
Length	2200 mm	7 ft 3 in
Width	1600 mm	5 ft 3 in
Height	2150 mm	7 ft 1 in

- Under roof mounted heating ventilating and air conditioning system
- Pneumatically cushioned and multi-adjustable comfort seat with lumbar support, seat heating, safety belt, head- and armrests
- Switch in seat cushion to automatically neutralize the hydraulic controls when operator leaves the seat
- Joystick controls integrated in independently adjustable seat consoles
- Fold-away auxiliary seat with safety belt
- FOPS (rock guard; approved according to DIN ISO 3449) integrated into cab structure
- All-round safety glass, armored windshield and sliding side window
- Windshield with parallel intermittent wiper/washer
- Roller blinds at all windows
- External sun shields at side and rear windows
- Robust instrument panel including large colored BCS screen with transfective technology
- Board Control System (BCS III); electronic monitoring, data logging and diagnostic system for vital signs and service data of engines, hydraulic system and lubrication system, featuring:
 - Robust instrument panel including large (12 in) colored touch screen for intuitive handling
 - On-screen PDF documentation (e.g. operating instructions, technical handbook, spare parts catalog, electric circuit diagram)
 - On-screen troubleshooting assistance
 - Graphic charts of logged data
 - Fault memory with storage of related conditions
 - USB, Lan (TCP/IP) and CAN BUS interfaces for data export
- Machine access via retractable access stairway, stairway angle approximately 45°, hydraulically operated
- Sliding emergency ladder (kick-down type) with ladder cage

Undercarriage

Travel speed (2 stages)		
1st stage – maximum	1.5 km/h	0.93 mph
2nd stage – maximum	2.5 km/h	1.55 mph
Maximum tractive force	2097 kN	471,260 lbf
Gradeability of travel drives – maximum	57%	
Track pads (each side)	42	
Bottom rollers (each side)	7	
Support rollers (each side)	2 plus a skid plate in between	
Travel drives (each side)	1 planetary transmission with 2 two-stage axial piston motors	
Parking brake	Wet multiple disc brake, spring applied/ hydraulically released	

- Cast double-grouser combined pad-links with bushings connected by hardened full floating pins
- All running surfaces of sprockets, idlers, rollers and track links, as well as teeth contact areas of sprocket and pad links, are hardened
- Fully hydraulic self-adjusting track tensioning system with membrane accumulator
- Automatic hydraulic retarder valve to prevent over-speed on downhill travel
- Acoustic travel alarm

Automatic Lubrication System

- | | | |
|------------------------------|--------|---------|
| Capacity of grease container | 1000 L | 264 gal |
|------------------------------|--------|---------|
- Dual-circuit system with hydraulically driven heavy-duty pumps and electronic time relay control adjust the pause/lube times
 - Connected to the lubrication system are:
 - raceways of the swing roller bearing
 - two greasing pinions for the internal gearing of the swing ring
 - pivot points of attachment, bucket and cylinders
 - System failures displayed by Board Control System
 - Grease filters (200 µm) between service station and container, as well as directly behind grease pump

Attachments

- Boom and sticks are torsion-resistant, welded box design of high-tensile steel with massive steel casting at pivot areas
- Welding procedures allow for internal counter-welding (double prep weld) wherever possible
- Boom and sticks are stress-relieved after welding
- Inspection hole in monoboom BH
- Guards for shovel cylinders (FS)
- Catwalks with rails at boom (FS and BH)
- Pressure-free lowering of boom (FS and BH) and stick (FS) by means of a float valve
- Shovel attachment with unique TriPower kinematics ensuring the following main features:
 - Horizontal automatic constant-angle bucket guidance
 - Vertical automatic constant-angle bucket guidance
 - Automatic roll-back limiter to prevent material spillage
 - Kinematic assistance to hydraulic forces
 - Constant boom momentum throughout the whole lift arc
 - Crowd force assistance
- All buckets (FS and BH) are equipped with a wear package consisting of:
 - Special liner material covering main wear areas inside and outside of bucket
 - Lip shrouds between teeth
 - Wing shrouds on side walls
 - Heel shrouds at bottom edges
- Special wear packages for highly abrasive materials on request

6040/6040 FS Hydraulic Shovel Specifications

Dimensions

All dimensions are approximate.

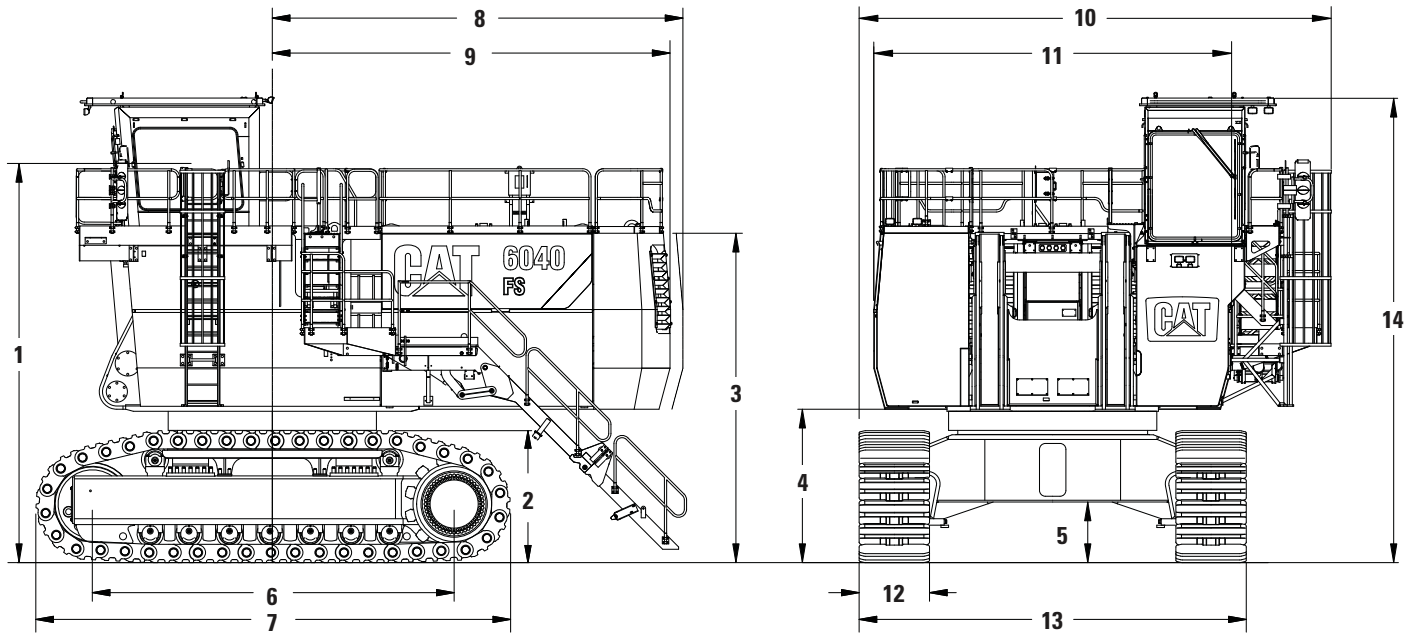

1	6800 mm	22 ft 4 in	8	7000 mm	23 ft
2	2250 mm	7 ft 5 in	9	6780 mm	22 ft 3 in
3	5620 mm	18 ft 5 in	10	8050 mm	26 ft 5 in
4	2620 mm	8 ft 7 in	11	6100 mm	20 ft
5	1030 mm	3 ft 5 in	12	1200 mm	3 ft 11 in
6	6170 mm	20 ft 3 in	13	6600 mm	21 ft 8 in
7	8090 mm	26 ft 7 in	14	7920 mm	26 ft

Dimensions and weights of AC machine differ slightly. Separate drawings, dimensions and weights can be provided upon request.

6040/6040 FS Hydraulic Shovel Specifications

Working Range – TriPower Face Shovel Attachment (FS)

All dimensions are approximate.

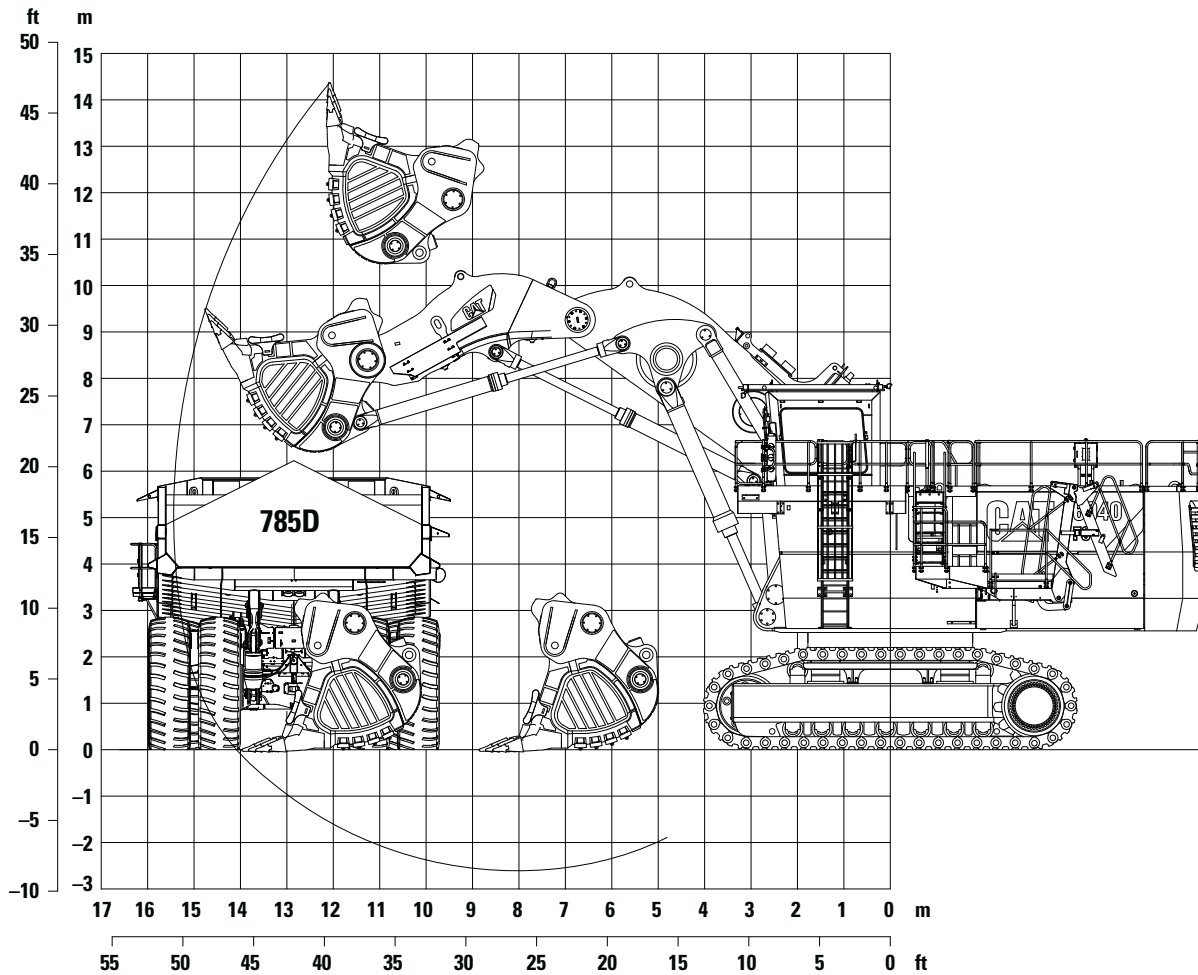

Boom	7.3 m	23 ft 11 in	Working Range	
Stick	4.6 m	15 ft 1 in	Maximum digging height	14.4 m 47 ft 3 in
Digging Forces			Maximum digging reach	15.4 m 50 ft 6 in
Maximum crowd force	1730 kN	388,780 lbf	Maximum digging depth	2.6 m 8 ft 6 in
Maximum crowd force at ground level	1200 kN	269,680 lbf	Maximum dumping height	10.9 m 35 ft 9 in
Maximum breakout force	1200 kN	269,680 lbf	Crowd distance on level	5.1 m 16 ft 9 in

Face Shovels

Type	Iron Ore Shovel		Heavy Rock Shovel		Heavy Rock Shovel		Standard Rock Shovel		Light Rock Shovel	
Capacity heaped 1:1	17.1 m ³	22.4 yd ³	20.6 m ³	26.9 yd ³	23.2 m ³	30.3 yd ³	25.3 m ³	33.1 yd ³	27.5 m ³	36.0 yd ³
Capacity heaped 2:1	15.0 m³	19.6 yd³	18.0 m³	23.5 yd³	20.0 m³	26.2 yd³	22.0 m³	28.8 yd³	24.0 m³	31.4 yd³
Total width	4220 mm	13 ft 4 in	4220 mm	13 ft 4 in	4680 mm	15 ft 4 in	4680 mm	15 ft 4 in	5020 mm	16 ft 6 in
Inner width	3840 mm	12 ft 7 in	3840 mm	12 ft 7 in	4300 mm	14 ft 1 in	4300 mm	14 ft 1 in	4640 mm	15 ft 3 in
Opening width	1940 mm	6 ft 4 in	1940 mm	6 ft 4 in	2010 mm	6 ft 7 in	2010 mm	6 ft 7 in	2010 mm	6 ft 7 in
Number of teeth	5		5		6		6		6	
Weight including wear package	34 000 kg	74,960 lb	34 500 kg	76,060 lb	36 400 kg	80,250 lb	37 300 kg	82,230 lb	37 600 kg	82,890 lb
Maximum material density (loose)	2.8 t/m ³	4,720 lb/yd ³	2.2 t/m ³	3,710 lb/yd ³	2.0 t/m ³	3,370 lb/yd ³	1.8 t/m ³	3,030 lb/yd ³	1.6 t/m ³	2,700 lb/yd ³

6040/6040 FS Hydraulic Shovel Specifications

Working Range – Backhoe Attachment (BH)

All dimensions are approximate.

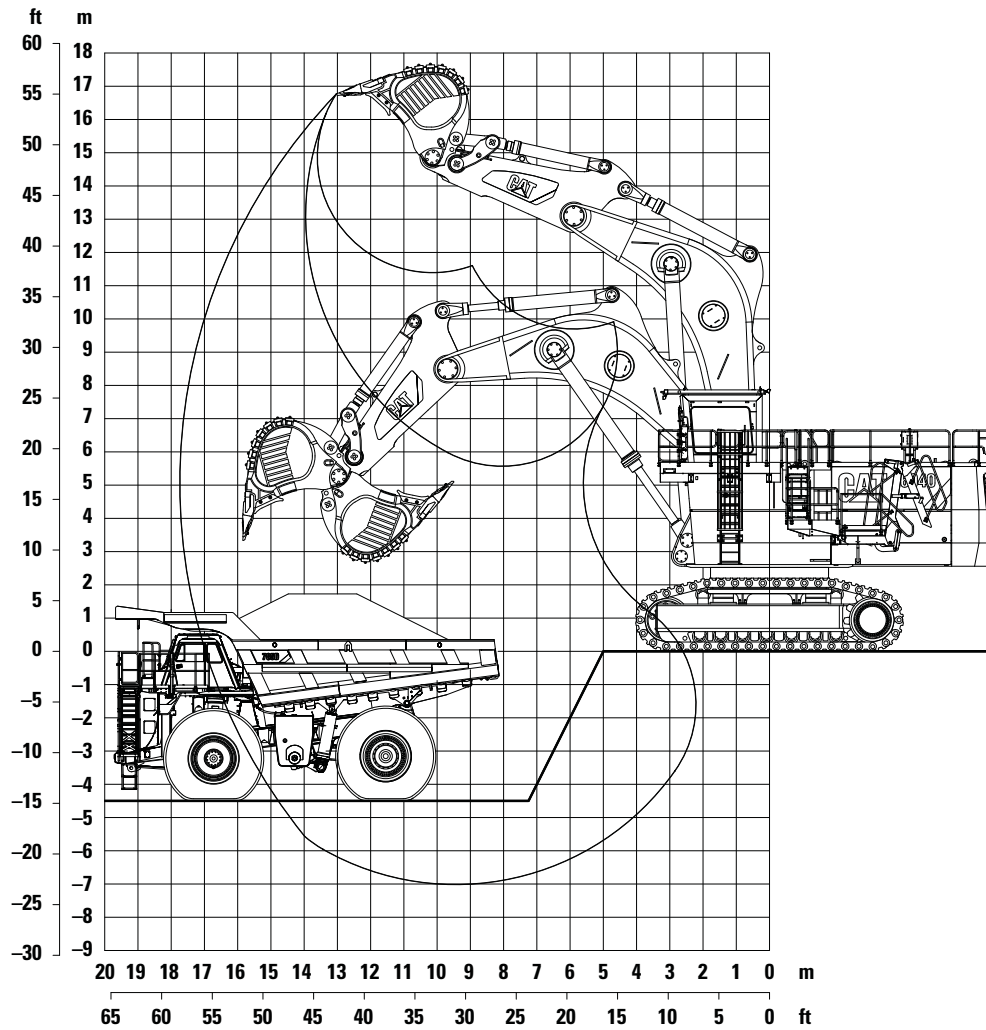

Boom	9.5 m	31 ft 2 in
Stick	4.6 m	15 ft 1 in
Digging Forces		
Maximum tearout force	1020 kN	229,220 lbf
Maximum breakout force	1120 kN	251,700 lbf

Working Range			
Maximum digging depth	7.0 m	23 ft	
Maximum digging reach	17.7 m	58 ft 1 in	
Maximum digging height	16.8 m	55 ft 1 in	

Backhoes

Type	Heavy Rock Bucket		Heavy Rock Bucket		Standard Rock Bucket	
Capacity heaped 1:1	18.0 m³	23.5 yd³	20.0 m³	26.2 yd³	22.0 m³	28.8 yd³
Capacity heaped 2:1	16.1 m ³	21.1 yd ³	17.7 m ³	23.2 yd ³	19.5 m ³	25.5 yd ³
Capacity struck	14.0 m ³	18.3 yd ³	15.3 m ³	20.0 yd ³	17.2 m ³	22.5 yd ³
Total width	4150 mm	13 ft 7 in	4150 mm	13 ft 7 in	4150 mm	13 ft 7 in
Inner width	3800 mm	12 ft 6 in	3800 mm	12 ft 6 in	3800 mm	12 ft 6 in
Number of teeth	6		6		6	
Weight including wear package	21 000 kg	46,300 lb	22 900 kg	50,490 lb	23 800 kg	52,470 lb
Maximum material density (loose)	2.2 t/m ³	3,710 lb/yd ³	2.0 t/m ³	3,370 lb/yd ³	1.8 t/m ³	3,030 lb/yd ³

Optional Equipment

Optional equipment may vary. Consult your Cat dealer for details.

GENERAL

- Custom paint

SUPERSTRUCTURE

- Hydraulic service crane on superstructure with auxiliary engine
- One or two round container(s) for standard 200 L (53 gal) barrels (instead of 1000 L (264 gal) grease container)
- Filling of round container(s) via service station
- Various cold-weather options

Additional optional equipment available on request.

CAB

- Dual (redundancy) heating ventilating and air conditioning system
- Cab heating
- Camera monitoring system

UNDERCARRIAGE

- Track pad width 1400 mm (4 ft 7 in) or 1600 mm (5 ft 3 in)
- Automatic lubrication of rollers by central lube system
- Cover plate under carbody (belly plate)

For more complete information on Cat products, dealer services, and industry solutions, visit us on the web at www.cat.com

© 2014 Caterpillar
All rights reserved

Materials and specifications are subject to change without notice. Featured machines in photos may include additional equipment. See your Cat dealer for available options.

CAT, CATERPILLAR, SAFETY.CAT.COM, their respective logos, "Caterpillar Yellow" and the "Power Edge" trade dress, as well as corporate and product identity used herein, are trademarks of Caterpillar and may not be used without permission.

AEHQ7162-01 (04-2014)
Replaces AEHQ7162

